

The Piano Keys weir: a new cost-effective solution for spillways

F. Lempérière, Hydrocoop, France
A. Ouamane, Biskra University, Algeria

Reprinted from

THE INTERNATIONAL JOURNAL ON
**HYDROPOWER
& DAMS**

Issue 5, 2003
Aqua~Media International Ltd
ISSN 1352-2523

The Piano Keys weir: a new cost-effective solution for spillways

F. Lempérière, Hydrocoop, France
A. Ouamane, Biskra University, Algeria

Free-flow spillways are simpler and safer than gated ones, but the low specific flow of their traditional shapes requires high spilling nappe depths and thus huge losses of storage ($100 \times 10^9 \text{ m}^3$ worldwide). A new shape of free-flow spillway (the "Piano Keys weir") can increase the specific flow fourfold or more. It could substantially reduce the cost of most new dams and increase, at low cost, the safety and the storage and/or the flood control efficiency of many existing dams.

Most existing free-flow spillways have a standardized shape (Creager weir) and are placed upon concrete gravity dam structures. Their drawback is their low specific flow which is (in $\text{m}^3/\text{s}/\text{m}$) close to $2.2 h^{1.5}$ (h being the nappe depth in metres).

Consequently, the loss of live storage corresponding to the maximum nappe depth may be 20 to 50 per cent, compared with a gated reservoir, even if using longer spillways than with gates.

It is thus very advantageous to increase the specific flow as much as possible. Some tens of existing spillways have been designed accordingly as vertical walls on a flat bottom, with a trapezoidal labyrinth layout which is much longer than the spillway length (often four times.) They usually double the specific flow of a Creager weir. They require 1 or 2 m^3 of reinforced concrete to increase the flow by 1 m^3/s , and have mainly been used for specific flows in the range of 10 $\text{m}^3/\text{s}/\text{m}$. Exceptionally, the Ute dam in USA increased the specific flow by 30 $\text{m}^3/\text{s}/\text{m}$; it required 60 m^3 of reinforced concrete per meter. Apart from its cost for high flows, the main drawback of the traditional labyrinth solution (vertical walls and flat bottom) is that it cannot be used on top of the usual concrete gravity dam sections and requires a substantially flat area. It can therefore only be used for a few dams and in fact has been used for one per thousand large dams.

Model tests for the P.K. weir at the French national hydraulic laboratory LNH (owned by Electricité de France).

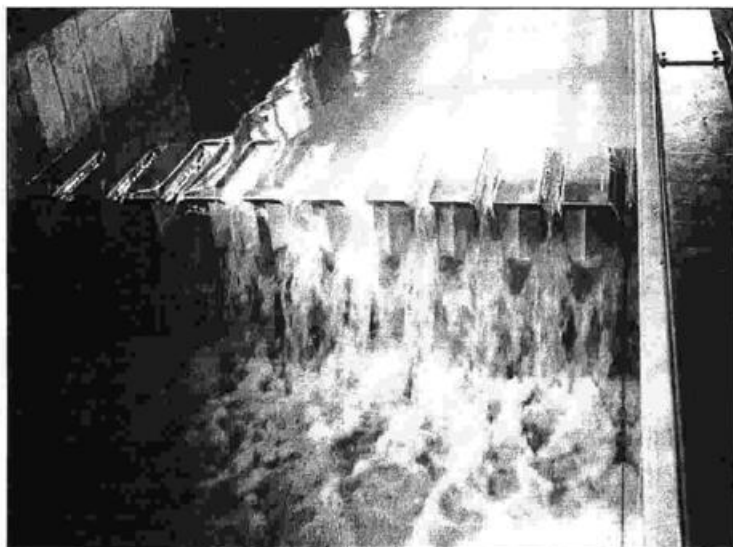

1. The P.K. weir design

A totally different design has been studied for five years by Hydrocoop (a non-profit-making international association), and this has been supported by more than 50 hydraulic tests. The target is a structure which:

- can be placed on existing or new gravity dam sections;
- will allow for specific flows of up to 100 $\text{m}^3/\text{s}/\text{m}$;
- can multiply at least by four the flow of a Creager weir; and,
- is structurally simple, and easy to build with the local resources of all countries.

Preliminary model tests were done in 1999 at the LNH Laboratory in France (owned by Electricité de France) and in 2002 at Roorke University in India and Biskra University in Algeria. Some shapes were then selected, and are based on:

- a rectangular layout somewhat similar to the shapes of piano keys which explains the name "Piano Keys weir" (thus "P.K. weir");
- an inclined bottom of the upstream and downstream part (the part where the flow enters is known as the inlet, and the other part the outlet); and,
- a reduced width of the elements.

Many detailed tests were then done in 2003 on selected shapes at Biskra University and some tests using a very wide flume at LNH.

These detailed tests provided the basis for optimizing the flow increases according to the ratios between length, depth, width and shape of the elements, and particularly according to the ratio (length of walls/length of spillway) N .

The impact of various overhangs has also been studied. Particular attention has been paid to the structural design and construction facilities for selecting the most attractive solutions.

Very simple longitudinal sections have at present been preferred: it is possible that refining these shapes may slightly improve the cost efficiency.

Further studies are now under way in China (at IWHR in Beijing) and India (Roorke University) as there are great possibilities for using P.K. weirs in these two countries.

Hydraulic and structural data are given next for two solutions.

- *Solution A*, with similar upstream and downstream overhangs; this favours the use of precast concrete elements, which may be used for specific flows of up to about 20 $\text{m}^3/\text{s}/\text{m}$. It may be preferred for this reason to improve many existing spillways.

• *Solution B*, with only an upstream overhang. Relevant savings are about 10 per cent higher than for solution A, and structural loads are less for high specific flows. It could thus be a very attractive choice for many future large dams.

It is likely that other designs based on the same principles could be more efficient, but the range of cost saving would probably not be very different. It could be interesting to choose, according to local conditions within each country, one or two basic solutions and to standardize drawings for various specific flows.

2. Hydraulic data

2.1 Model A

Model A is represented in Fig.1. Hydraulic data and savings are described next for a value of the wall height H equal to 4 m and are shown in Fig 3.

For other values of H , the specific flows and relevant saving should be multiplied by $(H/4)^{1.5}$, and the depth saving by $H/4$.

The length of elements is 12 m, the width of an element is $2 \times 2.40 = 4.80$ m. The ratio N between the total wall length (2×12 m + 4.8) and the spillway length 4.8 m is 6.

$N = 6$, $H = 4$ m, $L = 12$ m, Width = 4.80 m

For $H = 4$ m.

The required quantity of reinforced concrete is close to 4 m³ per metre of spillway. The increase of specific flow is 11 m³/s, that is, $1.4 H^{1.5}$.

The nappe depth saving is 1.7 m, that is, $0.42 H$.

These savings are significantly reduced for nappe depths of less than 1 m (or $0.25 H$) if this solution is used for multiplying a Creager weir flow by a coefficient R higher than 4 (for $N = 6$).

It is possible to increase the values N and R if narrowing the elements for the same length and depth. However, the cost increase is roughly proportional to the increase of N and the increase in the saving is progressively reduced. It will usually be advisable to use values of N lower than 10 (for R lower than 7.) It is also possible to increase the width of the elements. For instance, if it is increased from 4.80 to 8 m, N will become 4, the savings and costs will be reduced by about 30 per cent and the maximum value of R is limited to 2.5.

It is thus possible to choose the width according to the required value of R , N being higher than 1.5 R .

For model A, for the same overall width of the inlet and outlet, it is also possible for the same cost to increase inlet width by 20 per cent and to reduce, accordingly, the outlet width: the savings are increased by 5 per cent as compared with the figures above.

2.2 Model B

Model A has upstream and downstream overhangs, and Model B (see Fig. 2) has no downstream overhang but a larger upstream one. This solution has two advantages and one drawback:

- The specific flow is higher than for A for the same length, height and cost.
- The structural stresses are lower for upstream overhangs as the concrete weight reduces the water pressure impact instead of being added to it.
- But Model B does not favour the use of precast elements.

Model B is likely to be more attractive for new dams where high specific flows will be favoured and for very large existing spillways.

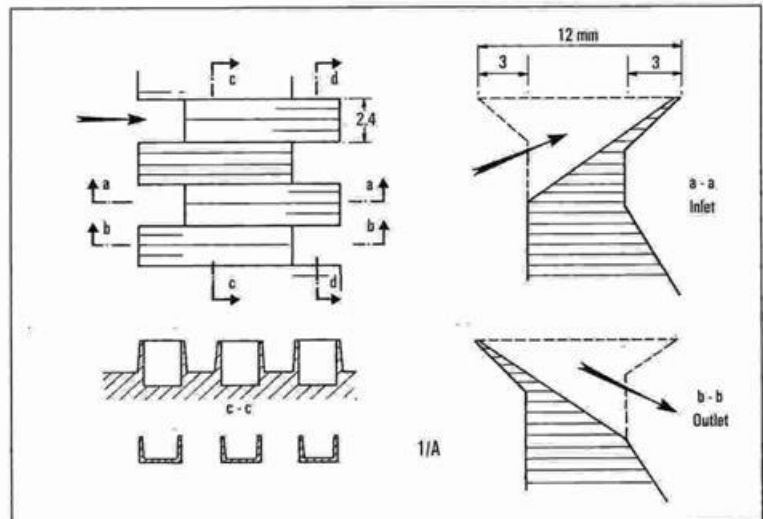

Data are given next for a wall height H of 8 m and are shown in Fig 3.

Length $L = 24$ m, Width $2 \times 4.80 = 9.60$

$N = (2 \times 24 \text{ m} + 9.60)/9.60 = 6$

For $H = 8$ m.

The required quantity of reinforced concrete is close to 20 m³/m of spillway. The increase of specific flow is 38 m³/s, that is, about $1.7 H^{1.5}$. The nappe depth saving is 4 m, that is, about $0.5H$.

These savings are significantly reduced for nappe depths of less than $(0.2 H)$ that is, if this solution is used for multiplying a Creager weir flow by a coefficient R higher than 4.5 (for $N = 6$).

As for model A, it is possible to modify the total width of the elements and the related savings and costs.

2.3 Models A and B

For models A and B:

- Increasing by 10 per cent the length or height for the same width of elements increases the savings and cost by about 5 per cent.
- Giving a better hydraulic shape to the vertical part of the inlet (Fig.4), as for the piers of a gated spillway, would increase the savings and flow increase by about 10 per cent for a small extra cost.
- Modifying the low part of the outlet (Fig. 5) does not substantially reduce the flow. This may favour the construction conditions.

Fig. 2. The layout for Model B.

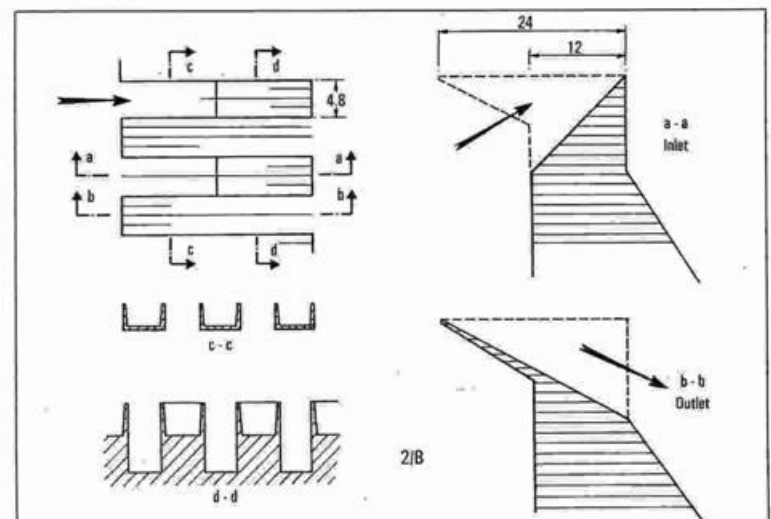
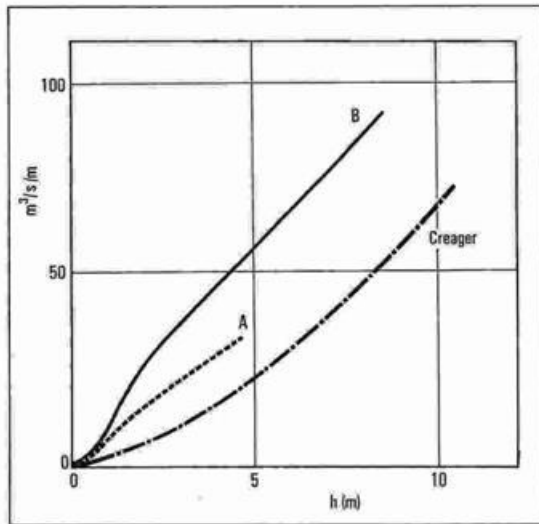

Fig. 3. Data for a wall height of 8 m.



- Floating trees or debris may reduce by about 10 per cent the flow when the nappe depth is in the range of 1 or 2 m (as for Creager weirs). For nappe depths of 2 m or more, the floating debris are washed away according to model tests.
- The flow is considerably aerated through a P.K. weir; the risk of downstream erosion or cavitation is thus greatly reduced. This is confirmed by model tests and existing labyrinth shaped spillways.

| Model A: Data for $H = 4$ m | | | | | | | | | | |
|--|------|-----|------|------|------|------|------|------|-----|------|
| 1. Nappe depth of P.K. weir (m) | 0.50 | 1 | 1.5 | 2 | 2.5 | 3 | 3.5 | 4 | 4.5 | 5 |
| 2. Specific flow of the P.K. weir ($m^3/s/m$) | 3.5 | 8.2 | 12.5 | 15.6 | 19.2 | 22.4 | 25.5 | 28.7 | 32 | 35.5 |
| 3. Specific flow of a Creager weir ($m^3/s/m$) | 0.8 | 2.2 | 3.9 | 6 | 8.8 | 11.4 | 14.5 | 17.7 | 21 | 24.5 |
| 4. Increase of specific flow 2-3 ($m^3/s/m$) | 2.7 | 6 | 8.6 | 9.6 | 10.4 | 11 | 11 | 11 | 11 | 11 |
| 5. Ratio of specific flows 2/3 | 4.4 | 3.7 | 3.2 | 2.6 | 2.2 | 2 | 1.8 | 1.6 | 1.5 | 1.4 |
| 6. Nappe depth of a Creager weir for the specific flow 2 (m) | 1.4 | 2.4 | 3.2 | 3.7 | 4.2 | 4.07 | 5.1 | 5.6 | 6 | 6.3 |
| 7. Depth saving 6-1 (m) | 0.9 | 1.4 | 1.7 | 1.7 | 1.7 | 1.7 | 1.6 | 1.6 | 1.5 | 1.3 |

| Model B: Data for $H = 8$ m | | | | | | | | | | |
|--|------|------|------|-----|------|------|------|------|------|------|
| 1. Nappe depth of P.K. weir (m) | 1 | 2 | 3 | 4 | 5 | 6 | 7 | 8 | 9 | 10 |
| 2. Specific flow of the P.K. weir ($m^3/s/m$) | 11.5 | 27.4 | 39.9 | 50 | 59.4 | 68.5 | 77.6 | 88.5 | 98 | 108 |
| 3. Specific flow of a Creager weir ($m^3/s/m$) | 2.2 | 6.2 | 11 | 17 | 25 | 32 | 41 | 50 | 59 | 69 |
| 4. Increase of specific flow 2-3 ($m^3/s/m$) | 9.3 | 21.2 | 28.9 | 33 | 34.4 | 36.5 | 36.6 | 38.5 | 39 | 39 |
| 5. Ratio of specific flows 2/3 | 5.2 | 4.4 | 3.6 | 2.9 | 2.5 | 2.1 | 1.9 | 1.8 | 1.7 | 1.6 |
| 6. Nappe depth of a Creager weir for the specific flow 2 (m) | 3.1 | 5.4 | 7 | 8 | 9 | 9.9 | 10.8 | 11.7 | 12.6 | 13.4 |
| 7. Depth saving 6-1 (m) | 2.1 | 3.4 | 4 | 4 | 4 | 3.9 | 3.8 | 3.7 | 3.6 | 3.4 |

3. Structural data and costs

Studies have been done for structures in reinforced concrete. Prefabricated steel structures could also be used for specific flows of less than $20 m^3/s/m$, but would probably be more expensive.

The main stresses in reinforced concrete are in the vertical walls between the inlet and the outlet; these walls act as overhangs over the concrete blocks, and not as horizontal beams, and it is even possible, to avoid thermal stresses, to design a vertical joint at the highest part of this wall.

The triangular shape of the wall (Fig.6) considerably reduced the stresses as compared with a rectangular wall; the thickness of the upper part of the wall may be small (10 to 20 cm). The average thickness of the reinforced concrete structure may thus be 15 to 25 cm for specific flows of less than $20 m^3/s/m$ and in the range of 50 cm for specific flow increases of $50 m^3/s/m$.

A P.K. weir as presented above, with a maximum wall height H , requires, per metre of spillway, a total area of reinforced concrete of $4.2H$. As the nappe depth saving is 0.4 or $0.5H$, the necessary volume of reinforced concrete for saving 1 m of depth along 1 m of existing spillway is about ten times the wall average thickness, that means it varies from $1.5 m^3$ for $H = 2$ up to $5 m^3$ for $H = 8$ m.

As the increase in specific flow is about $1.5 H^{1.5}$, increasing the flow by $1 m^3/s$ requires $0.35 m^3$ of reinforced concrete for $H = 2$; and $0.5 m^3$ for $H = 8$ (to be compared with $2 m^3$ for the traditional labyrinth for the UTE dam).

When using P.K. weirs for improving existing free-flow spillways, a quantity of ordinary concrete equal to 70 per cent of the reinforced concrete quantity should be added to the quantities given above.

For new dams, the extra cost as compared with a Creager weir is limited to the cost of the reinforced concrete: 0.3 or $0.4 m^3$ per m^3/s of the total spillway capacity.

Dozens of traditional labyrinth walls with a similar thickness have been in operation for a long time and have had no special maintenance problems. It is, advisable however, to use 350 or 400 kg of cement per m^3 of reinforced concrete and about 200 kg of steel, to guarantee a long life for the structure.

Construction methods may vary with the height of the structure as well as the local economic situation and labour costs. They may be chosen with the contractor and the detailed design can be adjusted accordingly. For structures higher than 4 or 5 m, the P.K. weir overhang can easily be built in horizontal steps of about 2 m height. Structures 2 to 5 m high may be precast with unit weights of few tons (for instance Fig. 7).

4. New dams

In many countries, the exceptional floods may be very high, and the level of safety required increases the capacity, and thus the cost, of new spillways, which may represent a large part of the total dam cost. Well adapted risk analyses and new solutions for spillways may allow substantial savings to be made.

Thirty years ago, most dams were designed for a design flood with an annual probability such as 10^{-3} . Above the relevant reservoir level, a margin of safety of some metres (the freeboard) was retained below the embankment crest, but the true probability of overtopping (and failure) was not analysed precisely.

It is now usual, and advised by ICOLD Bulletins, also to consider a 'check flood' of very low annual

probability (such as 10^{-5}) or a theoretical 'probable maximum flood' and to ensure that this check flood (often about twice the design flood) may be spilled without dam failure; but it is usually accepted that the corresponding reservoir level may be close to the embankment crest, as the flood failure usually requires an overtopping of the embankment crest of some hours by a nappe depth of 0.20 to 0.50 m. The freeboard is thus considerably reduced for the check flood.

Two basic solutions have been used for spillways:

Gated spillways

Gated spillways are most often preferred for capacities of more than $1000 \text{ m}^3/\text{s}$, radial gates being the most usual. The reservoir may be operated at the level of the design flood, but the cost of gates is high and adapted to the check flood, that is, to about three times the flood of 10^{-2} annual probability. Consequently, for a century two-thirds of the spillway capacity will probably never be used; however, this solution is not completely safe because the gates require careful maintenance and operation and redundancy of operating devices (including power supply).

Incidents during heavy rainfall are not uncommon, and total jamming of gates has caused the failure of some large dams: this risk appears to be the largest risk associated with gated dams, and jamming may be caused by mechanical or electrical problems, access, lack of operators, or wilful damage. In the case of total jamming of gates, new dams should thus be designed to discharge at least the annual flood over the gates or through an emergency spillway. This is obtained if the freeboard above the gates is half of the gates height, the flow over the gate being $(1/3)^{1.5}$, that is, about 20 per cent of the flow with all the gates open.

To avoid the operating cost of gates, various solutions involving automatic gates have been used worldwide, but their reliability is questionable as there are two risks: unnecessary opening, or total jamming. Consequently, they should be used only for small dams, or for a part of the total spillage capacity.

Free-flow spillways

To avoid the cost or risks associated with gates, two-thirds of the world's large dams and particularly most spillways with a discharge capacity of less than $1000 \text{ m}^3/\text{s}$ are free-flow spillways. Their operation is simple and safe, but the drawback of the usual shapes such as the Creager shape is the rather low specific flow: the flow per metre of spillway length (in $\text{m}^3/\text{s}/\text{m}$) is about $2.2 h^{1.5}$, h being the nappe depth in metres. A flow of $1000 \text{ m}^3/\text{s}$ under a 3 m depth thus requires 90 m of spillway length. Apart from the cost of a long spillway for embankment dams, the maximum nappe depth reduces the useful reservoir depth; and reducing, for instance, by 3 m a reservoir depth of 30 m, in fact reduces by about 30 per cent the live storage (or increases the dam cost by 20 per cent). The reduction in hydropower output may also be substantial. Multiplying by 3 or 4 the specific flow of the spillway when using the P.K. weir solution will very often be a major improvement. Examples are given next for spillways of $200 \text{ m}^3/\text{s}$, $1000 \text{ m}^3/\text{s}$ and $5000 \text{ m}^3/\text{s}$ discharge capacity.

For $200 \text{ m}^3/\text{s}$, a traditional spillway would be, for instance, 35 m long and the nappe 2 m deep. With a P.K. weir, the length may be reduced to 10 m, avoiding a side spillway to embankment dams. This would require about 60 m^3 of reinforced concrete in precast

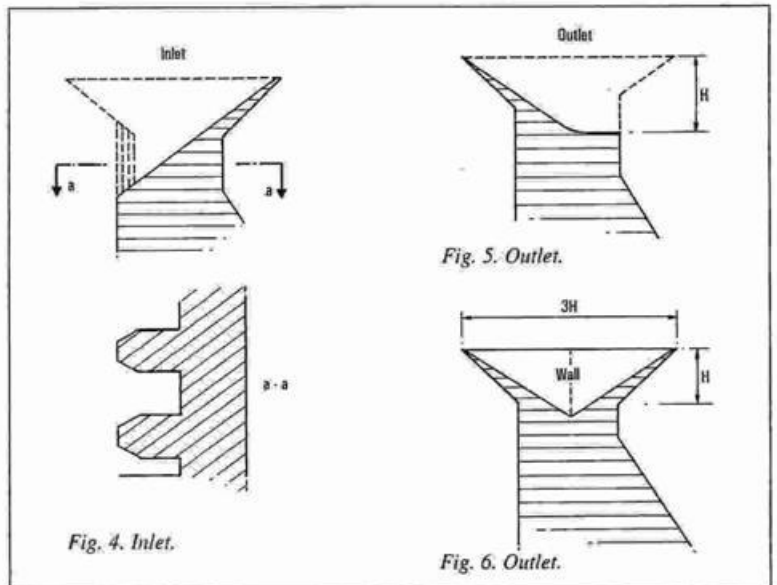

elements, less than US\$ 20 000 in many developing countries.

For $1000 \text{ m}^3/\text{s}$ of capacity, instead of a 90 m spillway 3 m deep, it is possible to use a 20 m-long spillway of the same depth or a 40 m-long spillway with a nappe depth of 2 m, using 300 m^3 of reinforced concrete in precast low-cost elements.

For a spillway with a design flood of $2500 \text{ m}^3/\text{s}$ and $5000 \text{ m}^3/\text{s}$ of check flood, a traditional design would use, for instance, four radial gates 12 m wide and 10 m high, with a freeboard of 5 m used for the check flood. The total length of the spillway, including piers, will be 60 m. In case of total jamming of the gates, the maximum flow over the gates will be $1000 \text{ m}^3/\text{s}$, approximately the annual flood. Four alternatives using P.K. weirs are suggested next:

- A P.K. weir about 80 m long with the sill level at the same level as the top of the gates. For the check flood, the level would be the same. The nappe depth of the P.K. weir would be, for the 100 year flood, about 1.5 m. it would be thus necessary to buy more land than with the gated dam, but the overall cost would be much lower, and the safety improved. This weir requires 2000 m^3 of reinforced concrete.
- A P.K. weir 50 m long and two flap gates, 6 m high and 12 m wide. This would add flexibility for managing the reservoir and controlling floods. The gates could be automatic, and the water level reduced for usual floods.
- A P.K. weir 50 m long and two low gates, 40 m² each; these gates could be placed 20 or 30 m below the

Figs. 4, 5 and 6. Variations to the hydraulic shape of the inlet and outlet.

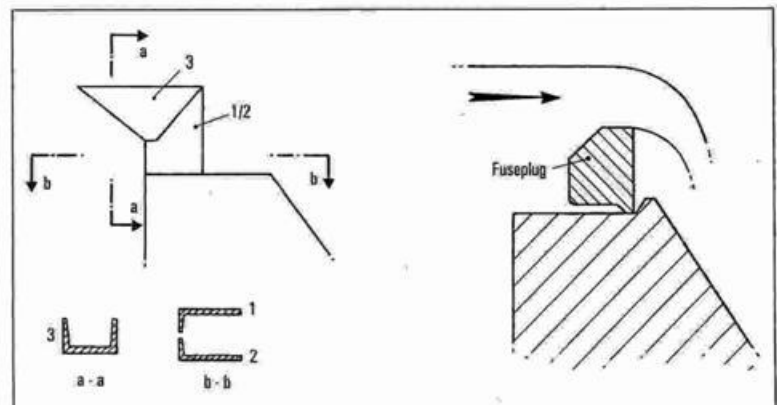

Fig. 7 (below left): construction using pre-cast elements. Fig. 8 (below): the use of a fuseplug to increase spillway capacity.

dam crest to control the reservoir and possibly to flush sediments.

- A P.K. weir 40 m long and two radial gates, as in the basic solution. The operating levels are the same as for the basic solution for all floods. This solution is substantially less expensive than the basic one. The total cost of the civil works is about the same, and half of the cost of the gates is avoided. In the event of total jamming of the gates, it would be possible to discharge the design flood.

For most new dams, at least one solution using P.K. weirs will thus be less expensive than traditional solutions, while maintaining or improving the safety. As there are no patents, these solutions may easily be implemented with the resources of each country.

P.K. weirs will probably be used more often for new dams, increasing the flow of a Creager weir by about four times and requiring 0.4 m³ of reinforced concrete per m³/s of total spillway capacity. The construction can be done by the main contractor, and the cost per m³/s would be about US\$ 100 in developing countries (to be spent in local currencies). The cost may be US\$ 300 to 500 in industrialized countries. This will make it possible to divide the spillway length of a free flow spillway by four or to reduce by 60 per cent the loss of storage. The combination of P.K. weirs with gates may also be very attractive.

5. Increasing the operating level of free-flow reservoirs

If the nappe depth for the design flood is h , it will be possible to raise the operating level by $0.6 h$ if lowering the sill by $0.9 h$ and installing P.K. weirs, of which the height H will be $1.5 h$.

As the value h is between 1 and 4 m for many existing dams, H will be usually between 2 and 6 m.

Increasing the operating level will require 2 m³ of reinforced concrete and 1.5 m³ of ordinary concrete per metre of spillway length for 1 m of reservoir level increase for most spillways.

The ratio between the area, of the reservoir in m² and the spillway length, L , in metres, is usually between 5000 and 50 000, often between 10 000 and 20 000 m³. The provision of 2 m³ of reinforced concrete will save 10 000 to 20 000 m³ of water storage. Taking into account also the cost of ordinary concrete and sill lowering, the cost per m³ of extra water storage will be in the range of US\$5 in most developing countries (to be spent in local currencies), and possibly five times more in industrialized countries where the cost of labour is much higher.

Where the area of a free-flow reservoir is more than 2 or 3 per cent of the catchment area, the volume stored in the nappe depth reduces the downstream flow peak. It is necessary in this case to reduce the nappe depth saving by the P.K. weir so as not to reduce the dam safety.

It should also be underlined that using a P.K. weir for existing dams reduces the time for floods downstream of the dam to peak, when the reservoir is not full at the beginning of the flood.

Using P.K. weirs in conjunction with gates as suggested in Section 7 avoids these drawbacks.

6. Increasing the capacity of existing free-flow spillways

It is often required to increase the spilling capacity of a free-flow spillway by 50 to 100 per cent, sometimes more. P.K. weirs can be used accordingly. For instance, if the nappe depth for the present design flood is h , lowering the sill by h and placing a P.K. weir to keep the same operating level will increase the flow by about 70 per cent, requiring, per extra m³/s, 0.5 m³ of reinforced concrete and 0.35 m³ of ordinary concrete, that is, a cost of about US\$ 150 in developing countries and US\$ 500 in industrialized countries.

It is possible to modify only a part of the spillway length according to the required flow increase.

7. Increasing storage and safety of existing dams

Safety authorities often wish to increase the spillway capacity, while dam owners mainly wish to increase the storage. It is possible to use P.K. weirs to increase the storage by 30 per cent of the present nappe depth and to increase the maximum discharge capacity by 50 per cent. The value of extra storage may pay also for the extra safety.

8. Increasing storage and flood control by existing free-flow reservoirs

For many existing reservoirs of area s (in m²) and a maximum nappe depth h (in m), the volume $s \times h$ is lost for storage and may represent 20 to 50 per cent of the live storage and a significant part of the flood volume. It is also poorly used for reducing the flow peak of floods downstream of annual probability 10^{-1} to 10^{-2} , that is, the main usual flood damage because the nappe depth is much less than h for these floods.

A very attractive solution may provide the advantages of a fully gated solution, without its cost and drawbacks. The sill of the existing spillway can be lowered by a depth equal to h ; P.K. weirs $1.5 h$ high will be placed along two-thirds of the spillway and a flap gate $1.5 h$ high along one-third.

The gate, which may be automatic, would be open for most of the flood season. A study of hydrograms shows a great reduction in the flow peaks downstream for most floods. The storage will be completed at the end of the flood season, and increased by $0.5 s h$. The maximum spilling capacity of the spillway is also increased. No permanent gate operator is necessary. The consequences of gate incidents will be greatly reduced compared with fully gated dams.

This solution, which has never been used, seems extremely attractive for thousands of existing dams, as the storage saving would also pay for an increase in dam safety and downstream flood control.

9. Emergency spillways

It is often necessary to add emergency spillways to existing gated spillways. Instead of adding costly gated emergency spillways, which do not avoid the risk of gates jamming, it could often be very advantageous to use a P.K. weir spilling the nappe depth corresponding to the freeboard. A P.K. weir may discharge for instance, a specific flow of more than 50 m³/s/m for a nappe depth of 4 m.

10. P.K. weirs in canals

P.K. weirs may be used on flat bottoms, as is the case with traditional labyrinth weirs, with a better cost efficiency, especially for large specific flows.

11. P.K. weirs compared with fuse devices

Various fuse devices have been used for the same purposes as considered above for P.K. weirs.

For new dams, P.K. weirs will usually be more attractive than fuse devices, but some fuse devices may be more interesting for some existing dams, for example:

- on top of arch dams, where placing P.K. weirs may be difficult; or,
- for cost reasons, as in the examples below.

Three fuse devices are considered, in the following paragraphs, with specific targets:

- Thousands of small dams in the USA use flashboards for increasing the storage of existing free-flow reservoirs. They are usually vertical woodboards, standing against vertical steel pipes embedded in the spillway sill concrete. The elements are usually about 1 m high or less. They may be withdrawn by hand before the flood season, or are overtopped by small floods and bend for the large floods (simple steel plates directly embedded in the sill may be an alternative). This solution is not expensive, but not precise, and requires some maintenance. It could be used for increasing free-flow reservoir storage by 0.5 to 1 m but, for safety reasons, the height of flashboards would be limited to 25 per cent of the gap between the spillway sill and the embankment crest, and the elements would bend for a water level well below the crest.

They may thus be more attractive than P.K. weirs only where the required increase in reservoir level is lower than 1 m.

- For increasing the spillway capacity of existing free-flow spillways, it is possible to lower the sill and place simple fuseplugs in ordinary concrete (see Fig. 8).

The thickness of the various elements would be, for instance, such that a first element would tilt for the present design flood and the last one for the check flood. This solution is patented in most industrialized countries, but it can be patent-free in most developing countries where its cost may be even lower than the cost of P.K. weirs for increasing the free-flow spillway capacity. They are less attractive for new dams, or for increasing the storage. They require about 0.5 m³ of ordinary concrete for increasing the flow by 1 m³/s.

- Fusegates are gravity elements which tilt when an uplift is created under them for a pre-determined upstream level. Their layout may be straight or labyrinth shaped. Structural costs are lower than for P.K. weirs, but their design is more complex and their patent requires payment in hard currency. They may be attractive as compared with P.K. weirs for improving existing large spillways.

The drawback of fuse devices is the loss of some elements and water, for instance, once per century. It may be attractive to use P.K. weirs for one half of a spillway and fuseplugs or fusegates for the other half, and to design the fuse devices for tilting only for a flood of low annual probability, such as 10⁻³.

12. Summary and conclusion

P.K. weirs are simple solutions as safe and easy to operate as traditional free flow spillways and much more efficient. They may:

- increase the specific flow fourfold;

- allow specific flows of up to 100 m³/s/m;
- reduce substantially the cost of most new dams and guarantee their safety;
- increase the storage of many existing reservoirs for a cost in the range of US\$ 5/m³ in most developing countries, and US\$ 25 in industrialized countries;
- improve the flood control by many existing dams; and,
- increase the spilling capacity of many existing dams with 0.5 m³ of reinforced concrete per extra m³/s.

The efficiency and cost can easily be checked within each country, and detailed designs can be standardized. There are no patents, and expenses can be in local currencies. ◊



F. Lempérière

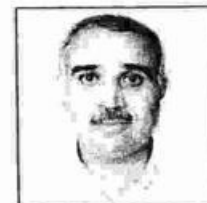

A. Ouamane

F. Lempérière has been involved in the construction or design of fifteen hydraulic schemes on large rivers including the Rhine, Rhone, Nile and Zambezi. He is Honorary Chairman of the French Committee on Large Dams. He has been Chairman of the ICOLD Committee on Costs of Dams (1991-2001). He is Chairman of Hydrocoop, a non-profit-making international association for technical exchanges.

Hydrocoop, 4, Cité Duplan, 75116 Paris, France.

A. Ouamane has been a lecturer since 1986 at the Hydraulic Department of Biskra University, Algeria. He is Head of Research at the Hydraulic Laboratory. He has conducted various theoretical and experimental studies on shaft weirs, stepped weirs and labyrinth weirs.

Department of Hydraulics, University of Biskra, BP 918 RP 7000, Biskra, Algeria.